

#66 – TRUSS BLOCKING AT RAISED HEEL CONDITIONS OR STRUCTURAL FASCIA AND SOFFIT

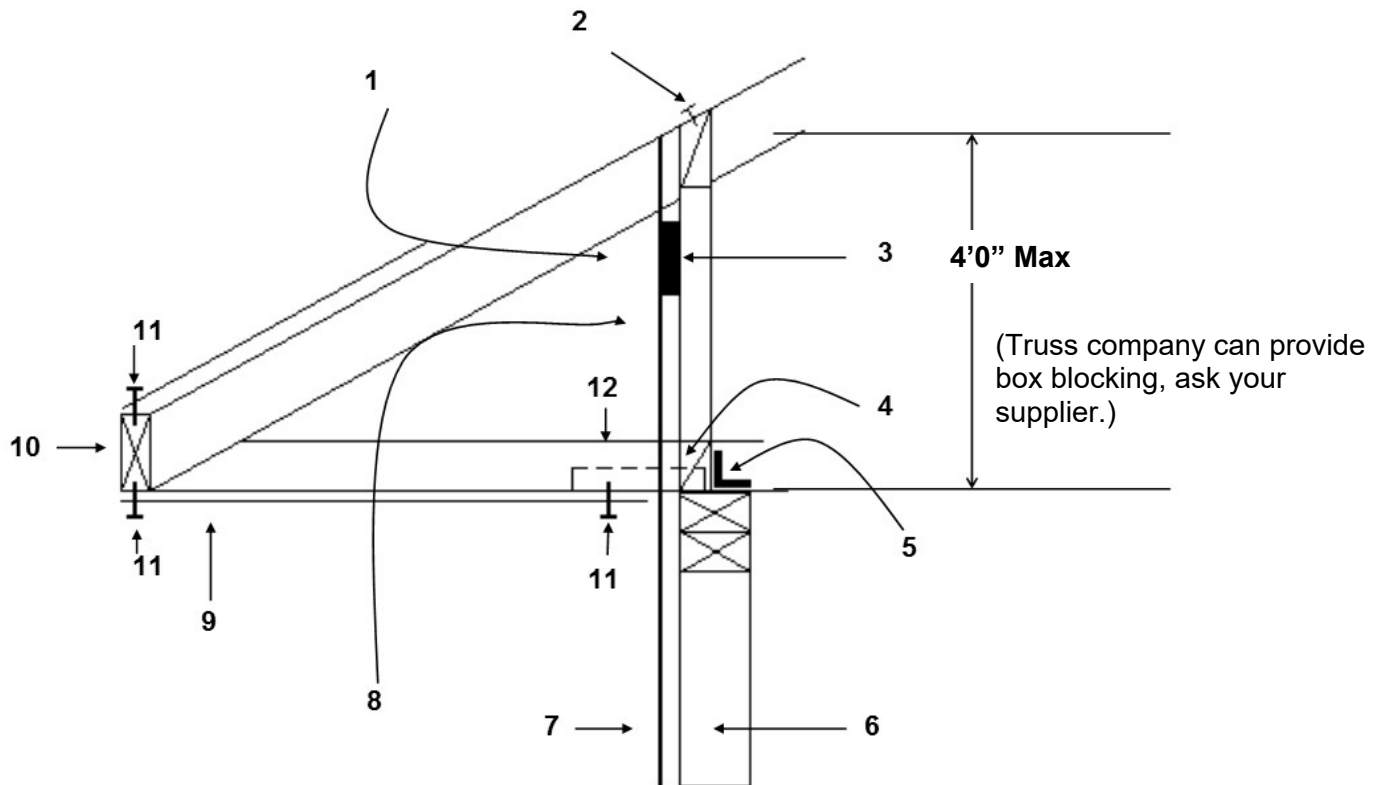

1. (3) 2" screened holes for venting in each truss space (if needed)
2. 2x4 horizontal block between truss top chords: nail roof sheathing to block 8d @ 6" o.c.
3. 2x4 verticals between trusses; nail OSB wall sheathing to blocks & verticals with 8d @ 6" o.c.
4. 2x4 horizontal block between truss bottom chords with (3) 8d nails or (1) A35 (or equal) connecting block to top plate
5. Exterior wall; roof sheathing must connect via this box block detail
6. 7/16" OSB wall sheathing
7. 7/16" OSB – nail to box-block frame perimeter 8d @ 6" o.c.

Only one type of blocking systems is required.
Items #8 through #11, are NOT required if items #1 through #7 are completed.

8. 7/16" OSB (or equal) structural soffit panel board
9. 2X4 structural sub-fascia
10. 8d nailing @ 6" o.c. (same nailing as standard roof sheathing edge nailing)
11. 2X6 or 2x8 flat block to connect soffit to double top plate – this block must overlap onto top of double top plate and nail into top plate using 10d @ 6" o.c. (overlap towards soffit just enough for soffit to have nailing.)