

CEMENT CONCRETE DRIVEWAY

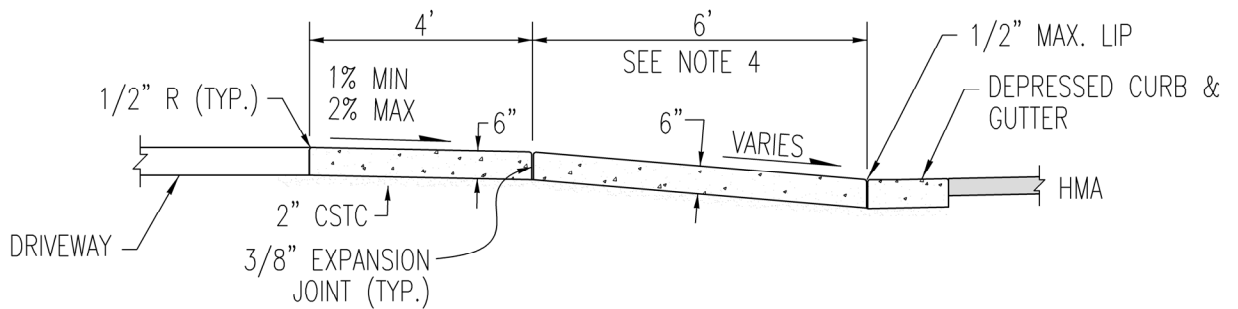

SECTION A-A

NOTES:

1. SEE STANDARD DETAIL ST7 FOR CURB, GUTTER AND SIDEWALK NOTES.
2. WHEN THE DRIVEWAY WIDTH EXCEEDS 15', CONSTRUCT A FULL DEPTH EXPANSION JOINT WITH 3/8" JOINT FILLER ALONG THE DRIVEWAY CENTERLINE. CONSTRUCT EXPANSION JOINTS PARALLEL WITH THE CENTERLINE AS REQUIRED AT 15' MAXIMUM SPACING WHEN DRIVEWAY WIDTHS EXCEED 30'.
3. SEE RMC 12.04.095 THRU 12.04.120 FOR ADDITIONAL DETAILS
4. THIS DIMENSION MAY BE REDUCED TO AS LOW AS 4'. REDUCTION REQUIRES VARIANCE REQUEST APPROVED BY CITY ENGINEER.
5. DRIVEWAYS CONTROLLED WITH YIELD, STOP CONTROL DEVICES OR TRAFFIC SIGNALS SHALL HAVE DETECTABLE WARNING SURFACES COMPLYING WITH R305.2.8. REFER TO PROWAG R205.7 FOR MORE DETAILED INFORMATION.

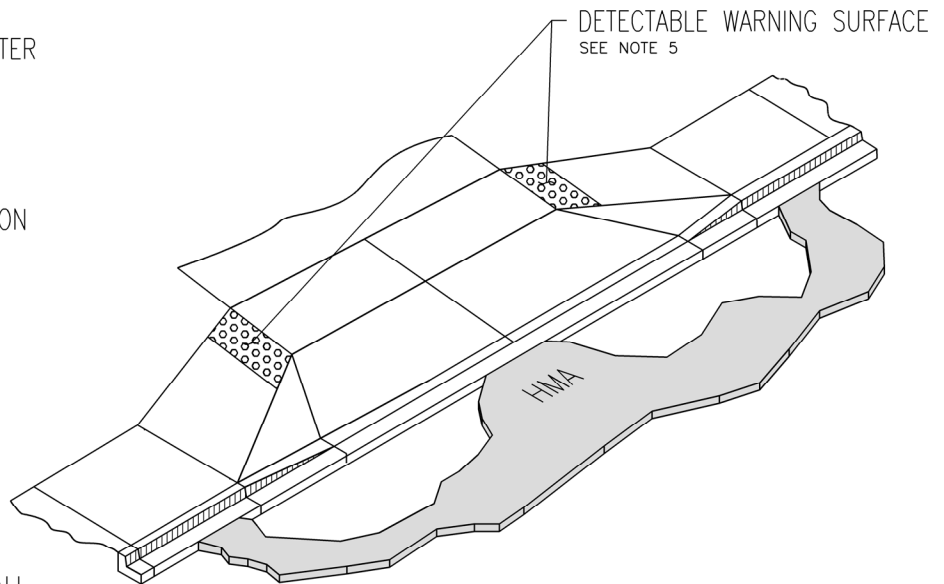

ISOMETRIC VIEW



**STANDARD
NON-RESIDENTIAL
DRIVEWAY (TYPE 2)**

PUBLIC WORKS ENGINEERING	
APPR. BY: SAW	DATE: 09.24
DRAWN BY: JLR	DWG: ST3A
CAD FILE: 2013_ST3A_09_2024	