

CULVERT INSTALLATION ALONG CITY OF RICHLAND STREETS WHERE NO CURB AND GUTTER EXIST

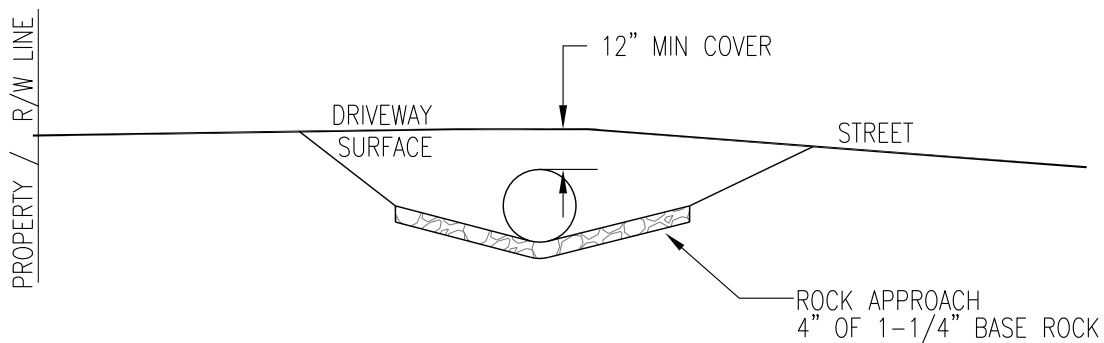

NOTES:

1. CULVERT PIPE SHALL BE 12" EXTRA STRENGTH CMP.
2. SIDE SLOPES OF DITCH SHALL BE 3:1 MAXIMUM.
3. CULVERT INSTALLATION SHALL PASS A CITY PUBLIC WORKS INSPECTION PRIOR TO FINAL ACCEPTANCE.
4. DITCH SHALL BE RE-ESTABLISHED ACROSS THE ENTIRE FRONTAGE PRIOR TO FINAL ACCEPTANCE.

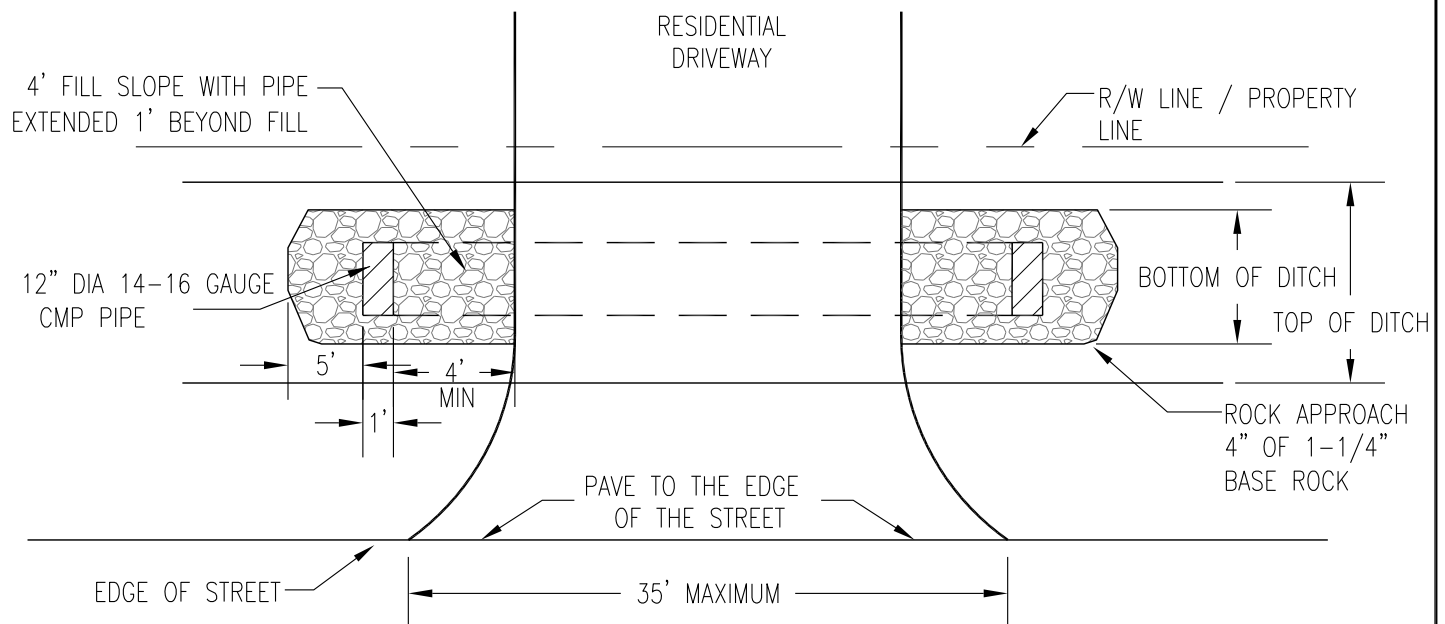
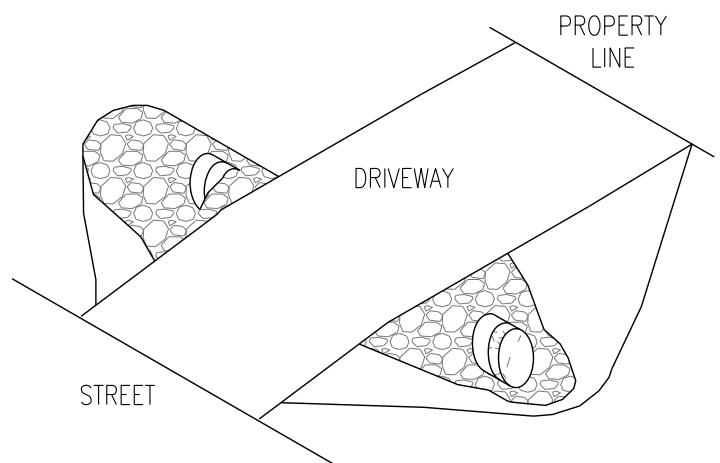

RURAL DRIVEWAY / CULVERT DETAIL

PUBLIC WORKS ENGINEERING	
APPR. BY: JR	DATE: 02.12
DRAWN BY: JG	DWG: ST22
CAD FILE: 2012_ST22_02_2012	