

**CASING SPACER**

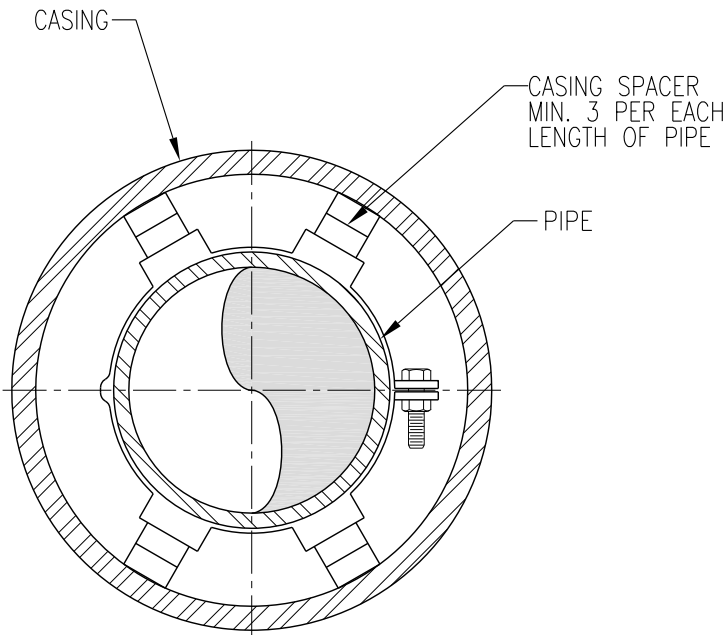

**SECTION A-A**

**NOTES:**

1. CASING SPACERS SHALL BE MANUFACTURED GALVANIZED OR STAINLESS STEEL, SIZED FOR THE TYPE OF PIPE & CASING SIZE PER THE MANUFACTURERS RECOMMENDATION.
2. CASING TO BE SIZED TO PROVIDE MINIMUM 2" CLEARANCE FOR THE TYPE OF JOINT APPROVED BY THE CITY ENGINEER.
3. PIPE JOINTS WITHIN CASING TO BE RESTRAINED JOINT AS APPROVED BY THE CITY ENGINEER.
4. FOR PIPES 12" & SMALLER, 2 SPACERS PER JOINT OF 13' SEWER, 4 SPACERS PER JOINT OF 18' OR 20' WATER.
5. MINIMUM 3/8" THICK STEEL CASINGS MAY BE REQUIRED BY THE RAILROAD OR IRRIGATION UTILITY.



**CASING SPACER**

PUBLIC WORKS ENGINEERING	
APPR. BY: PKR	DATE: 12.2010
DRAWN BY: SC NYBY	DWG: W17
CAD FILE: 2012_W17_12_2010	