



## ELECTRICAL UTILITY CONSTRUCTION REQUIREMENTS FOR PLATS & LAND DEVELOPMENT

This information packet provides information relating to utility infrastructure requirements for the development of real estate subdivisions and development of land for sale. The scope covered includes extension of electrical lines to and within the development, street light specifications, and the coordination issues relating to joint use trenches.

### I. GENERAL INFORMATION

#### A. POLICIES

1. **LINE EXTENSIONS:** Extension of lines to and within real estate subdivisions and developments of land for sale shall be provided by the City of Richland (the City). Energy Services shall design the electrical distribution system to and within the applicant's property. The developer is required to install a complete underground conduit and vault system at no cost to the City as a condition of service. Upon acceptance of the underground infrastructure Energy Services shall install cable, transformers, and other equipment to complete the extension of lines.

The developer shall be required to pay the City, as a construction payment, all estimated cost necessary for a complete electrical system. The construction payment is the estimated cost of Energy Services' portion of the construction including labor, materials, overheads, and taxes to complete your project. The construction payment is due when the construction permit is issued. The construction payment may be refundable to the applicant in part or in its entirety during a five-year period commencing with the extension's completion date, after which any remaining construction payment becomes non-refundable. For a complete explanation of this policy see the attached "*Special Provisions for the Extension of Electrical Utility Facilities to Residential Subdivisions and Multi-Family Units.*" The developer is required to sign the "*Special Provisions Letter of Understanding*" to indicate your acceptance of the design and the conditions of the City's extending lines.

The developer shall furnish and install all conduit, bedding, backfill, and vaults per City specifications for a complete underground conduit and vault system. After the installation of the electrical system any changes in the grade that put the cable, conduits, vaults or equipment at a depth less than required or leaves the installation in an undesirable condition will require the developer to correct it at the developer's expense. The developer shall be responsible for the conduit system for the same five-year period as the construction payment refund.

2. **STREET LIGHTING:** The City's Civil Engineering Division will determine if publicly owned street lighting is required for subdivisions or other land development. When publicly owned street lighting is required, the developer shall design and install a complete street light system that conforms to the Energy Services street light specifications at no cost to the City.

## **B. PRELIMINARY PLANNING PROCESS**

1. Contact Planning and Development Services Division for procedure to obtain preliminary plat approval.
2. After preliminary plat approval, submit plans for the public infrastructure to the Civil and Utility Engineering Division. For information on this procedure a handout titled "*Public Infrastructure Construction Plan Requirements and Design Guidelines*" may be obtained at the front desk of said department.
3. Provide Energy Services with an electronic copy in AutoCad 2007 of the preliminary plat. Energy Services will design the layout for the backbone electrical system and provide a copy to the developer. The developer will then incorporate the electrical layout into their design and drawings. After the submitted plat has been approved Energy Services will determine the fees for the construction payment.
4. Charter Cable TV, Frontier, and Cascade Natural Gas will also be sent the electrical facility plans to coordinate between the other utilities. Typically, Cable TV and Frontier often share the electrical power trenches. Cascade Natural Gas can share trenches with electrical facilities as long as the required separation clearances are maintained.
5. Street light systems are to be designed and installed by the developer to City standards. For complete information please obtain the below listed attachments from Energy Services or on line:
  - *Technical Specifications for Street Lighting<>TS- STRTLT.*
  - *Material Specifications for Street Lighting<>MS-STRTLT*

## **C. DESIGN CONSIDERATIONS**

1. A 10 ft. front lot line utility easement is required along all roads as well as anywhere else primary or secondary electrical cables are to be installed. Service runs within the lot they serve do not require an easement.
2. At lot corners where transformers are located only cable TV and telephone facilities are permitted. Avoid placing any other facilities except streetlight disconnects in this location. It is advisable to get the electrical facilities designed as soon as possible so that other utilities can be designed for installation at other corners.
3. Trench alignments shall be kept as straight as possible minimizing the number of bends. Individual conduit runs shall not contain more than 270° of sweeps.
4. Cable TV and telephone pedestals shall maintain a 3' minimum separation from any electrical equipment.

5. The preferred location of gas lines would be on the opposite side of street from electrical facilities.
6. Street lights shall be placed 2' behind sidewalk and 2' ft. ± into one lot from an extension of the side lot line. Street light junction boxes shall be placed directly behind street light pole.
7. Fire hydrants shall be located a minimum of 5' from electrical equipment.

#### **D. CONSTRUCTION AND INSPECTION REQUIREMENTS**

1. After the construction permit is issued a pre-construction conference will be scheduled through the City's Civil and Utility Engineering Division.
2. When the pre-construction conference is scheduled a Public Works' Inspector and Energy Services Project Engineer will be assigned to the project. All correspondence, verbal and written, relating to the electrical system, shall be through the Energy Service's Project Engineer.
3. Materials for the electrical conduit and vault system shall be furnished and installed by the developer and shall meet Energy Services specifications or as listed herein by the manufacturer (or approved equal).
4. The developer is responsible for placement of conduit and vaults at the depths, elevations, and alignments as indicated herein and on attachments. The developer shall coordinate with Power Operations (509-942-7421) for all inspections or approvals of the conduit and vault system. If any work requiring inspection, testing, or approval is covered without the Power Operations Inspector's approval, it must (if requested by the Inspector) be uncovered for inspection and if necessary replaced at the developer's expense. Property pins, survey stakes, elevation stakes, etc. must be maintained such that the Inspector or Project Engineer can verify transformers, vaults, etc. are properly placed during punch list inspection.
5. At all transformer, vault, and pedestal locations, the trench must be dug to a specific grade to bottom of trench such that the vault when set will be at the correct finished grade relative to back of future sidewalk.
6. The location of the ends of all conduits stubbed for future use shall be marked with a red painted 2x4.
7. The developer is responsible to coordinate placement of other utilities sharing the utility trenches.
8. Energy Services staking sheets and plan drawings show the basic plan, routing, and location of the various units of electrical equipment. Some allowance must be made for clarity due to scale. For example, ducts are shown projecting an exaggerated distance into property and wires and conduits are shown out of easement or into road right of way. If any doubt arises as to location, grade elevation, routing, etc. of any electrical conduits or equipment, within or outside of the City's right-of-way, contact the project engineer to resolve the situation.

9. The developer will guarantee all work to be free of defects for a period of five years. After the acceptance of the conduit and vault system and prior to the end of the five-year term, the developer shall repair defective work, correct settling and correct any undesirable conditions without cost to the City.

## **E. PROVISIONS FOR SHARED TRENCHES**

1. Clearance from gas pipe to any electrical utility pipe or structure shall be 24-inch horizontal and 12-inch vertical. In limited locations the 24-inch horizontal clearance can be reduced to not less than 12-inch to allow for an unavoidable conflict.
2. Trench depth and width begin to taper approximately 20 feet from transformer and vault locations to allow sufficient space for all utilities.
3. Electric service conduit stubs shall end approximately 7 feet behind front property line and 5 feet from side property lines. This places the conduit stubs behind the front lot line common trench used for electrical utility and gas lines that cross the property.
4. Relative placement of utility infrastructure:
  - a. Below Ground: Power and communication utility lines shall lay randomly, without separation, in the trenches where all utilities use conduit raceway. Where direct bury cable is used by any of the utilities there shall be a 24-inch clearance separation from the direct bury wire and the utility lines. Gas will be located on a shelf dug 12 inches above other utilities and 24 inches or more to the property side of trench. Where shelving trench cannot be done, then gas lays on property side of trench maintaining above stated horizontal clearances. See DWG #2 & #3.
  - b. Above Ground: Transformer pads are located 6 inches  $\pm$  behind sidewalk and 1 ft.  $\pm$  into one lot from an extension of the side lot line. Cable TV locates their pedestal in adjacent lot approximately 1 ft. behind transformer and 1-1/2 ft. into lot to centerline pedestal from side lot line. Maintain 3 ft. clearance from transformer. See DWG #1 & #3.

## **II. MATERIALS**

### **A. PVC CONDUIT**

Conduit shall be Electrical, Gray, Schedule 40 PVC, conforming to NEMA TC-2 specifications. All pipe and fitting joints shall be glued with PVC cement as recommended by the manufacturer. Conduits shall have deep sockets. See below for conduit ordering specifications.

Conduit ordering specifications for various PVC conduit sizes:

3" PVC - Conduit, 3" PVC, Sch. 40, 20' lengths, extruded bell end, UL 651 & NEMA TC2, min bell depth 4".

4" PVC - Conduit, 4" PVC, Sch. 40, 20' lengths, extruded bell end, UL 651 & NEMA TC2, min bell depth 4.5".

5" PVC - Conduit, 5" PVC, Sch. 40, 10'/20' lengths, extruded bell end, non UL, min bell depth 5".

6" PVC - Conduit, 6" PVC, Sch. 40, 10'/20' lengths, extruded bell end, non UL, min bell depth 6".

## INSTALLATION

The developer shall provide all trenching and backfill as required for the conduit and vault system. The developer is also responsible for the installation of the primary and secondary conduit system per Energy Services specifications. Soil around vaults and any trench within road right-of-way shall be compacted to 95% density per ASTM D-698.

The conduits and vaults shall be a complete system, cleaned and ready for the installation of cable, switch cabinets, transformer etc. Conduits shall penetrate V11 & V19 vaults through vault terminators unless otherwise authorized by the project engineer. Conduits shall extend a minimum of 2"-3" into vault.

The conduit may be deflected to follow the trench in large radius applications as long as the maximum deflection allowed by the manufacturer is not exceeded. The Developer shall not bend conduits using heating techniques. If the deflection required is greater than what is allowed by the manufacturer a standard sweep shall be used.

A mandrill or missile of suitable diameter with respect to pipe size shall be pulled or blown through conduit to insure pipe is clean of debris and has not been crushed. A measured/numbered Kevlar pull string or tape (minimum 1800# breaking strength) shall be installed in all conduits, except 3" service conduits to lots. Conduits shall not be covered until inspected by the Energy Services Inspector.

The Developer shall provide clear asbuilt information, on spare drawings used specifically for that purpose, updating the documents as the work progresses.

## **B. PVC CONDUIT FITTINGS**

All necessary fittings shall be factory made Gray, Electrical, Schedule 40 PVC, with extruded bell ends with Deep Sockets and conforming to NEMA TC-3 specifications.

All horizontal sweeps must be 36" minimum radius for 1½", 3", & 4" & 5" conduit. 6" conduit installations require a minimum radius of 48" for sweeps.

**For 1 ½" & 3" vertical sweeps up into transformers, pedestals, and junction boxes, 36" minimum radius sweeps must be used. Sweeps may be trimmed so that they extend 4-6" above the bottom of the vault or above final grade for pedestals.**

All conduit fittings must be deep socket. See below for conduit fitting ordering information:

1 ½" 3", 4", 5", & 6" PVC COUPLING - PVC Coupling, deep socket, Sch. 40, double bell are allowed.

1 ½", 3", 4", 5", & 6" PVC ELBOW - PVC Elbow, [22 ½°, 30°, 45° or 90°], Sch. 40, extruded bell end, deep socket are allowed.

## INSTALLATION

The basic design of conduit installation should allow for straight runs of conduit with very little use of sweeps. Where horizontal sweeps are required, long radius sweeps shall be used unless otherwise specified in the individual project drawings. When it is required to conform to trench alignment, grade, or to align conduits entering vaults the Developer shall use the minimum angle standard needed. There shall be no more than 270° of sweeps in any conduit run. Consult with Project Engineer before adding sweeps.

### **C. VAULTS**

Energy Services only accepts concrete vaults and lids from the following vendors which manufacture vaults to the Energy Services specifications. No other vaults or lids will be acceptable. Always specify "Vaults per City of Richland Specs" on all orders to insure correct items.

1. Hanson Pipe and Products, Inc.
2. H2 Pre-cast, Inc.
3. Utility Vault

See DWG #15 for contact and ordering information.

### VAULT NOMENCLATURE AS USED ON CONSTRUCTION DRAWINGS

Concrete vaults shall be designated on the staking sheets with a vault base size (i.e. V3B, V11B, V19B etc.) combined with a lid type (i.e. V3KO, V11STL, V19STLS etc.). Therefore, the designation indicates an assembly of a vault base and lid. Vaults shall be designated on the staking sheets as follows;

1. V3B concrete vaults. (36" x 42"x 30" deep). See DWG #9
  - a. V3STL - a 36" x 42" x 4" thick concrete lid with a 24" x 36" steel door.
  - b. V3KO - a 36" x 42" x 4" thick concrete lid with a 12" x 25" knock-out section which single phase padmount transformers are installed.
2. V11B concrete vaults. (56" x 56" x 42"Deep). See DWG #10
  - a. V11STL - a 56" x 56" x 6" thick concrete lid having a 36" x 36" locking steel door.
3. V19B concrete vaults. (56" x 84" x 48"Deep). See DWG #11
  - a. V19STLS - a 56" x 84" x 12" thick concrete lid having two - 36" x 36" locking steel doors.
  - b. V19SWT- a 66" x 84" x 12" thick concrete lid with a 50" x 62" opening which switch cabinets are installed.

For any situation involving three-phase transformers, please refer to the information handout "*Service Requirements-Commercial and Industrial Business Developments*" available from the City's Electrical Engineering Department or on line.

## INSTALLATION

The concrete vaults are to be set level and parallel with property line, back of sidewalk, curb, and pavement or as shown on engineer's drawings for the particular job. On residential plats vaults, transformers and pedestals are typically installed at lot corners, in street right of way and approximately 1 ft. ± into one lot from an extension of the side lot line. (Vaults shall not be located over a property line). See DWG. #1.

Vaults shall be set such that the top of lid is 2" ± above designated grade, with grade being typically back of sidewalk, top of curb, existing ground level, or as indicated on engineering drawings. Where sidewalks or curbs slope, set lid 2" ± above high or uphill side of slope. Open vault tops such as switch rings shall be overlain and secured by 3/4" plywood for security and safety purposes.

V11 & V19 Vaults shall be set on 6" of 5/8" minus crushed gravel compacted to 95% density per ASTM D-698. Ground wire and ground rods shall be installed by Energy Services crews after vault installation is inspected. See DWG #12.

### **III. DRAWINGS & SPECIFICATION FOR RESIDENTIAL TRENCHING & UTILITIES**

DWG #1 - Facility Location for Transformers, Vaults & Pedestals

DWG #2 - Typical Plat Overall Plan View

DWG #3 - Typical Conduit Separation – (Plan View) Transformer Location

DWG #4 - Residential Road Crossing Trench Detail

DWG #5 - Transformer Communication Pedestal Location

DWG #6 - Water & Sewer Services Relative to Electrical

DWG #7 - Protocol for Conduit Penetrations into Vaults

DWG #8 - Street Light Base & Junction Box Relative to Electrical

DWG #9 - V3 Concrete Vault

DWG #10 - V11 Concrete Vault

DWG #11 - V19 Concrete Vault

DWG #12 - V11 & V19 Vault Compacted Gravel Base

DWG #13 - Fiberglass Secondary Junction Pedestal With Service Connections

DWG #14 – Trench Detail

DWG #15 – Vender List

#### IV. ADDITIONAL INFORMATION

The following materials are available by contacting Energy Services:

- Electrical Equipment Clearances
- Special Provisions For Extension Of Electrical Utility Facilities To Residential Subdivisions And Multi-Family Units
- Technical Specification For The Installation Of Street Lighting – TS-STRTLT
- Material Specification For Street Lighting – MS-STRTLT

<b>Revision Description</b>				
<b>Rev.</b>	<b>Reason for Revision</b>	<b>Change Description</b>	<b>Affected Pages (Page/Sec./Para.)</b>	<b>Date</b>
0	Initial Issue		All pages.	12/14/10
1	Editing & Format	Updated letterhead & made various grammar edits	All pages	7/16/18
2	Updated Drawing	Updated drawing # 11	DWG #11	9/24/18



# TYPICAL PLACEMENT OF ELECTRICAL EQUIPMENT AT PROPERTY LINES & NEAR INTERSECTIONS OR CURVES

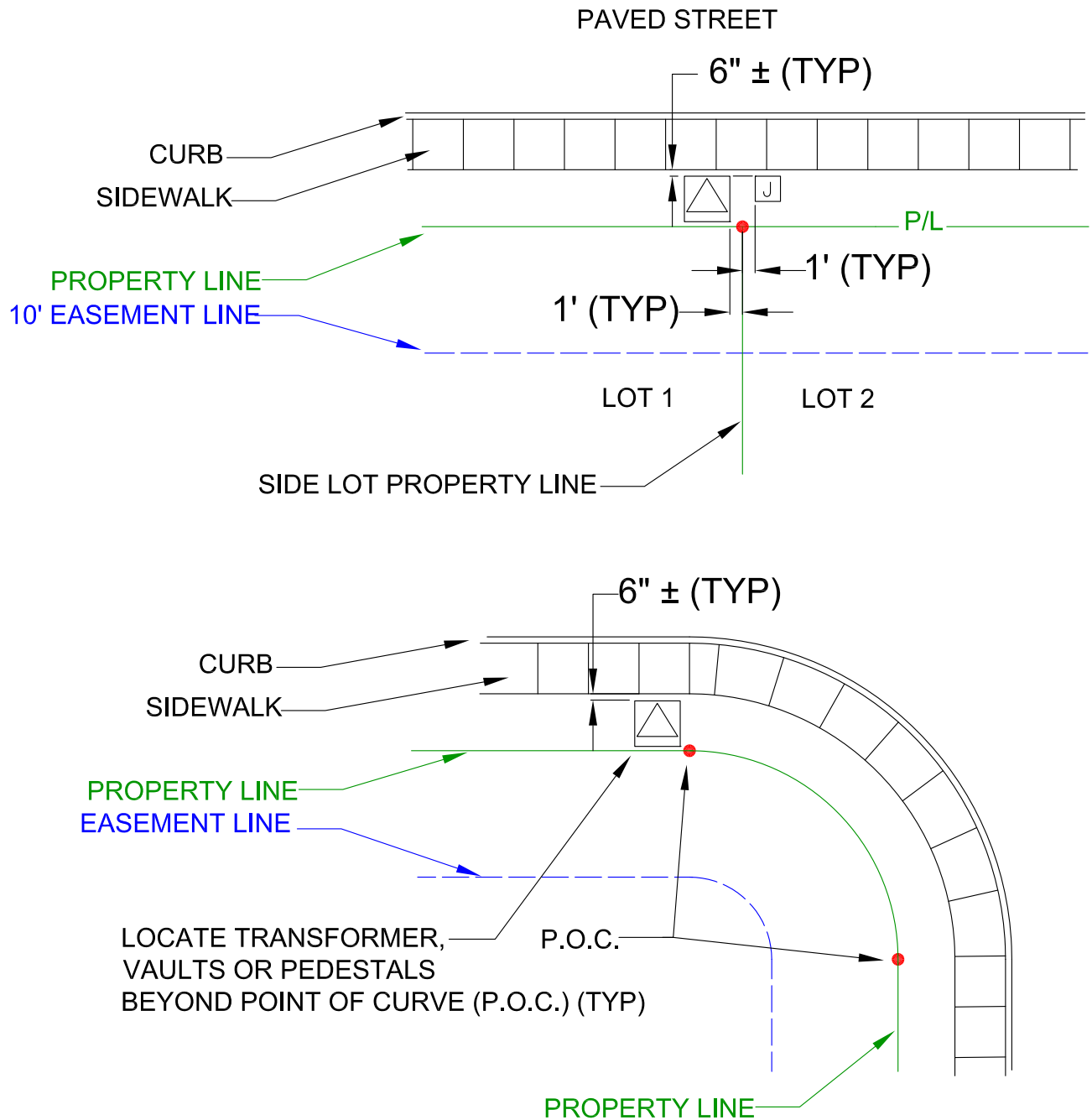

NOTE 1: TRANSFORMERS, VAULTS AND PEDESTALS SHALL BE SET LEVEL, PARALLEL TO AND WITHIN 6" ± OF SIDEWALK (TYP) AND 1' (ONE FOOT) INTO EITHER LOT'S FRONTAGE.

NOTE 2: GRADE FOR VAULTS AND TRANSFORMER PADS IS 2"± ABOVE REFERENCE FEATURE, TYPICALLY BACK OF SIDEWALK. GRADE FOR SECONDARY PEDESTALS SHALL BE THE GROUND LEVEL MARKINGS ON THE PEDESTAL'S SIDE.

DRAWN BY: WR	<b>FACILITY LOCATION DETAIL FOR TRANSFORMERS, VAULTS &amp; PEDESTALS</b>	<b>ENERGY SERVICES</b>
APPRD. BY: KDH		
REV #: 1		
		12/17/2010 <b>DWG #1</b> SHT: 1 OF 1

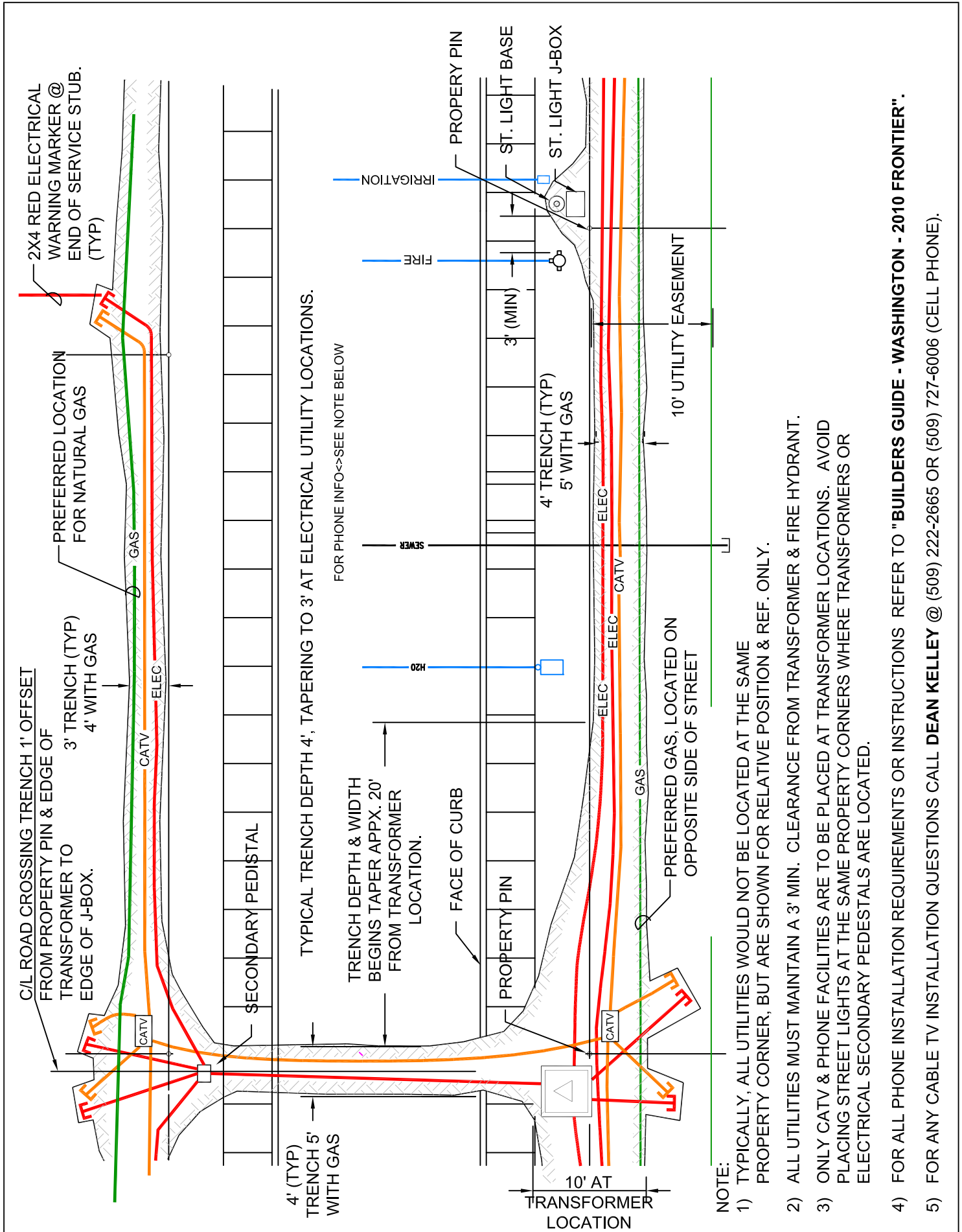

DRAWN BY: WR  
 APPRD. BY: KDH  
 REV #: 1

**TYPICAL PLAT OVERALL  
(PLAN VIEW)**

**ENERGY SERVICES**

**DWG #2**  
 SHT: 1 OF 1

12/17/2010

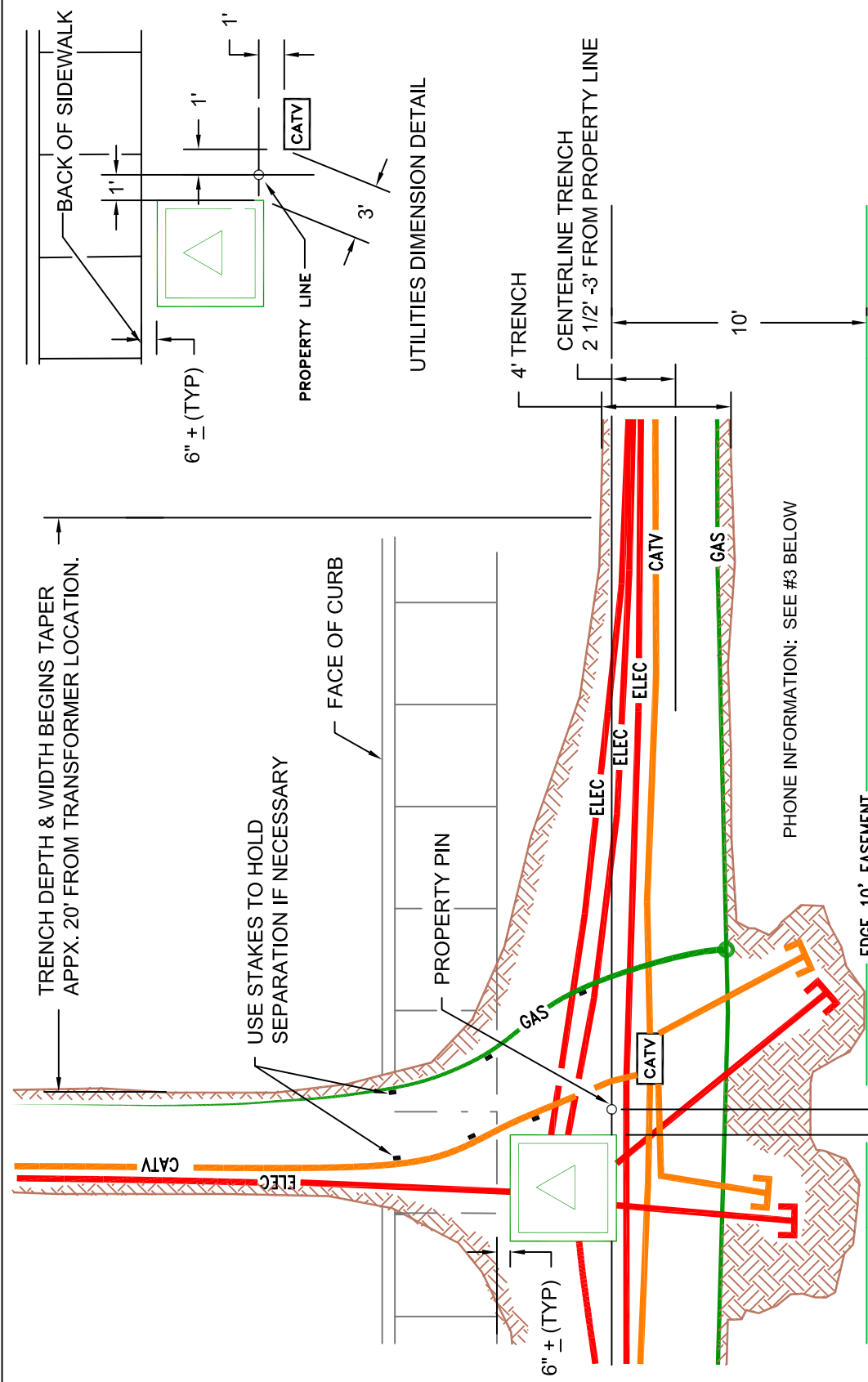

NOTES:

- 1) ONLY CATV & PHONE FACILITIES ARE TO BE PLACED AT TRANSFORMER LOCATIONS. STREET LIGHTS SHALL NOT BE PLACED AT TRANSFORMER LOCATIONS.
- 2) PREFERRED GAS LOCATED ON OPPOSITE SIDE OF STREET BUT WHEN NECESSARY TO SHARE TRENCH, GAS MUST MAINTAIN 2' HORIZONTAL & 1' VERTICAL SEPERATION
- 3) FOR ALL PHONE INSTALLATION INSTRUCTIONS OR REQUIREMENTS REFER TO "BUILDERS GUIDE-WASHINGTON-2010 FRONTIER".
- 4) FOR ALL CABLE TV INSTALLATION QUESTIONS CALL DEAN KELLEY @ (509) 222-2665 OR (509) 727-6006 (CELL PHONE).

DRAWN BY: WR
APPRD. BY: KDH
REV #: 1

TYPICAL CONDUIT SEPARATION  
(PLAN VIEW) TRANSFORMER LOCATION

**R** ENERGY SERVICES

12/17/2010

**DWG #3**  
SHT: 1 OF 1

FUTURE TRANSFORMER LOCATION  
 FUTURE CATV PEDISTAL

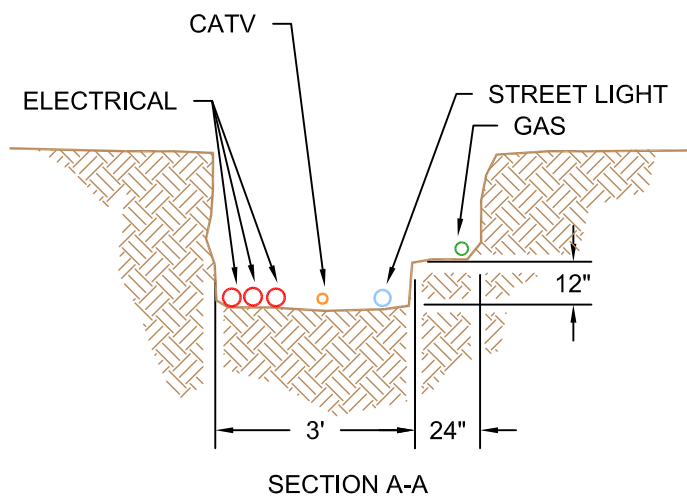
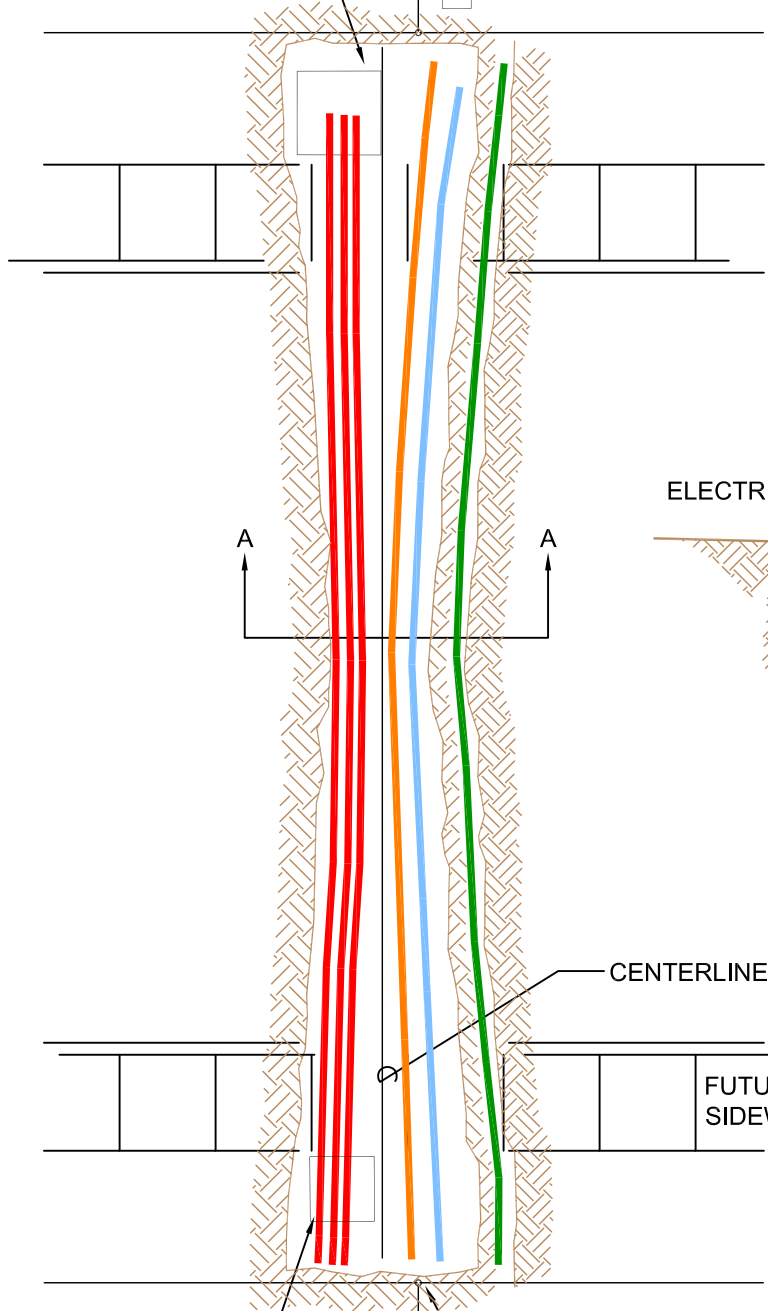

NOTE: 2' (MIN) SEPERATION BETWEEN NATURAL GAS & OTHER UTILITIES.

NOTE #1: FOR ALL PHONE INSTALLATION INSTRUCTIONS OR REQUIREMENTS REFER TO "BUILDERS GUIDE-WASHINGTON- 2010 FRONTIER".  
 NOTE #2: FOR ALL CABLE TV INSTALLATION QUESTIONS CALL DEAN KELLEY @ (509) 222-2665 OR (509) 727-6006 (CELL PHONE).

DRAWN BY: WR	<b>RESIDENTIAL ROAD CROSSING          TRENCH DETAIL</b>	 <b>ENERGY          SERVICES</b>
APPRD. BY: KDH		
REV #: 1		

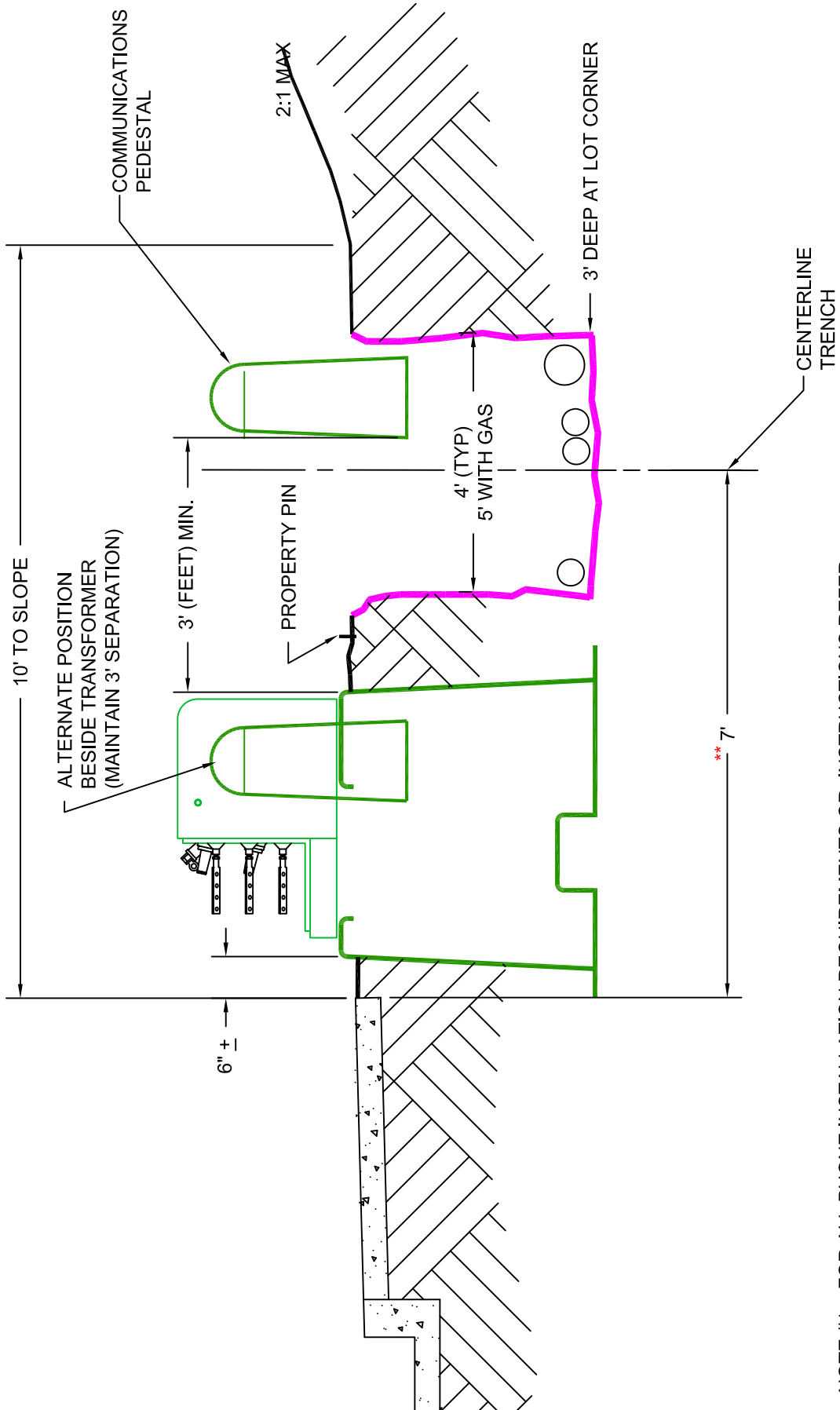

NOTE #1: FOR ALL PHONE INSTALLATION REQUIREMENTS OR INSTRUCTIONS REFER TO "BUILDERS GUIDE-WASHINGTON- 2010 FRONTIER".

NOTE #2: FOR ANY CABLE TV QUESTIONS CALL DEAN KELLEY @ (509) 222-2665 OR (509) 727-6006 (CELL PHONE).

\*\* DIMENSION CAN VARY DEPENDING UPON RIGHT OF WAY WIDTH BUT CENTERLINE TRENCH IS TYPICALLY 2 1/2'-3' INTO PROPERTY.

DRAWN BY: WR

APPRD. BY: KDH

REV #: 1

TRANSFORMER / COMMUNICATION  
PEDESTAL LOCATION



ENERGY SERVICES

12/17/2010

DWG #5

SHT: 1 OF 1

# WATER & SEWER TRENCH DETAIL

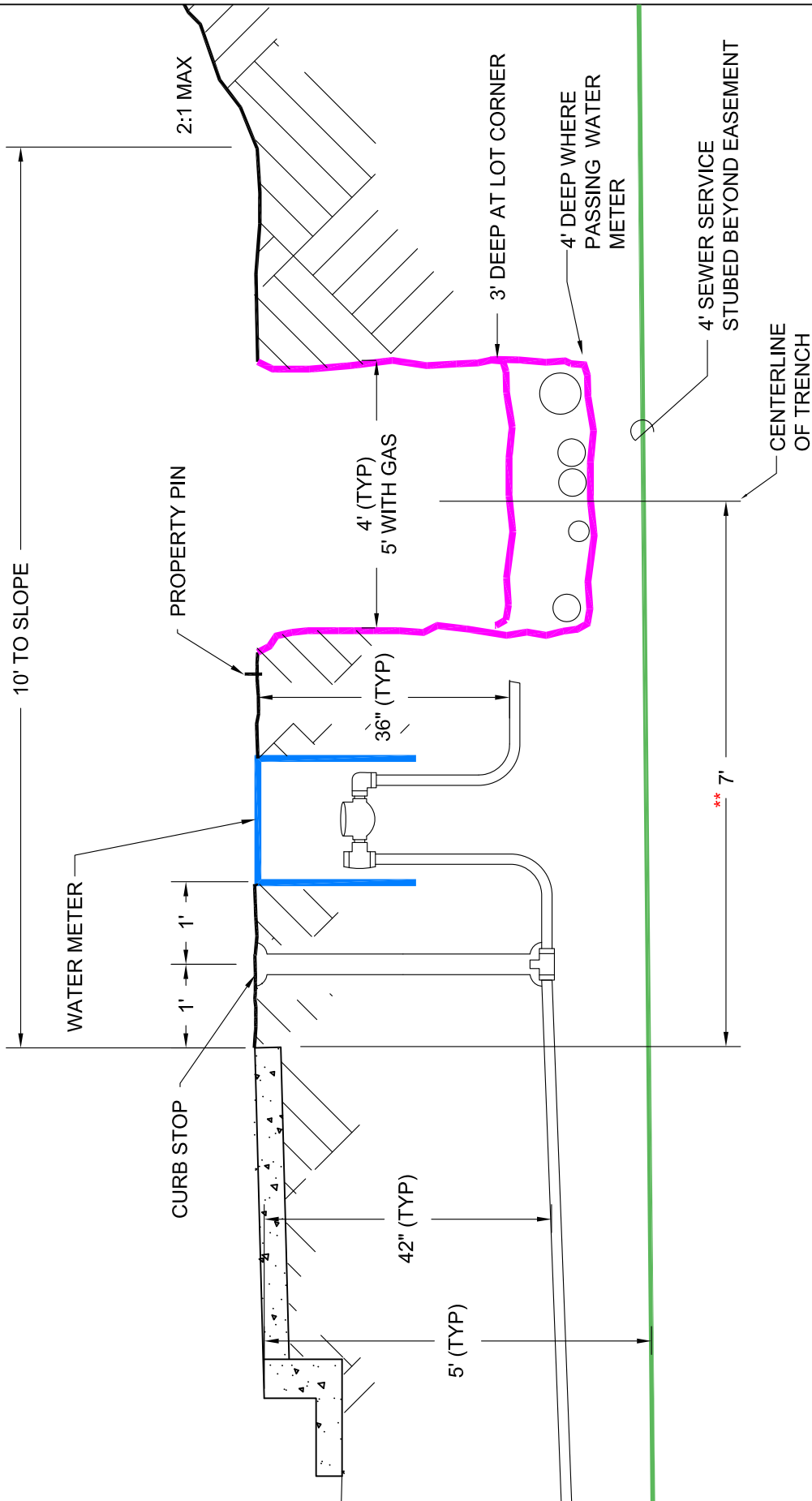

**NOTES:**

- 1) TYPICAL MID LOT TRENCH CROSS SECTION SHOWING WATER METER AND DEEPER TRENCH TO GET PIPES LOWER THAN WATER METER PIPES.
- 2) WATER METERS TYPICALLY INSTALLED MID TRENCH AND NEAR LOT CORNERS NOT OCCUPIED BY TRANSFORMERS.

**\*\* DIMENSION CAN VARY DEPENDING UPON RIGHT OF WAY WIDTH BUT CENTERLINE TRENCH IS TYPICALLY 2 1/2'-3' INTO PROPERTY.**

DRAWN BY: WR

APPRD. BY: KDH

REV #: 1

## WATER & SEWER SERVICE RELATIVE TO ELECTRICAL



**ENERGY SERVICES**

12/17/2010

**DWG #6**

SHT: 1 OF 1

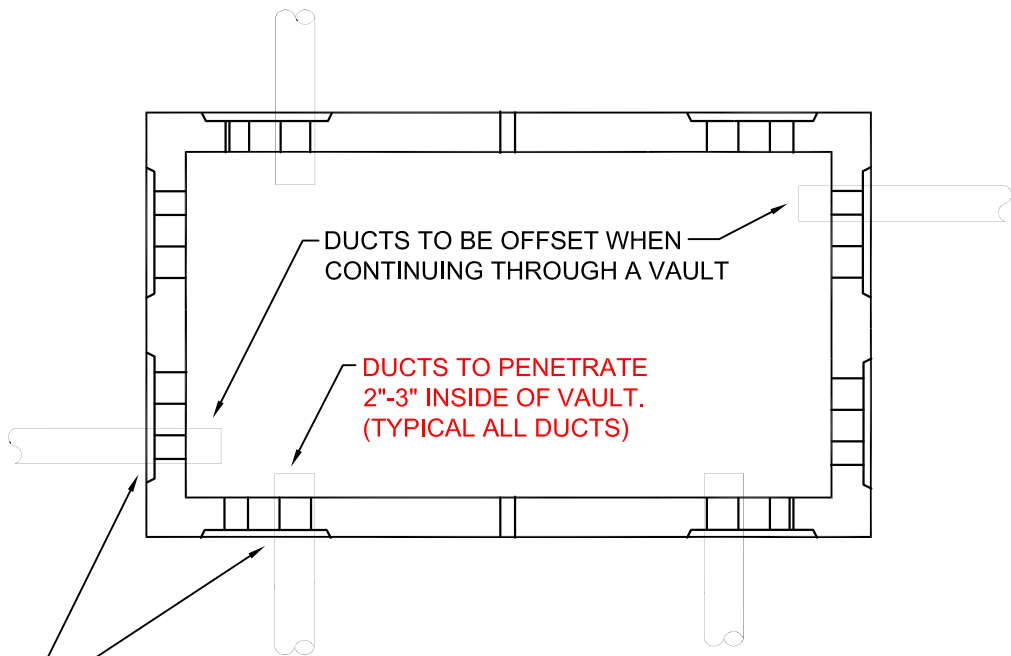

WHENEVER POSSIBLE, AVOID DUCTS PENETRATING ON ADJOINING SIDES OF CORNER.

### DUCT PENETRATION PROTOCOL FOR V11 AND V19 VAULTS (PLAN VIEW)

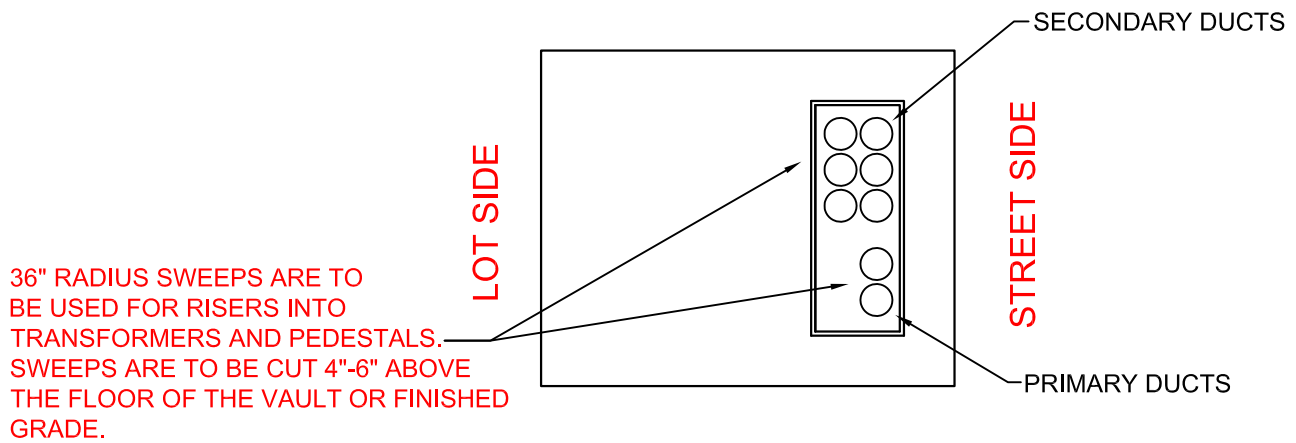

### DUCT DETAIL FOR V3KO TRANSFORMER INSTALLATIONS (PLAN VIEW)

NOTE 1: IN RESIDENTIAL PLATS, GROUNDING SHALL BE INSTALLED BY ENERGY SERVICES CREWS AFTER INSPECTION OF VAULTS.

2: CONTRACTOR MAY NOT PENETRATE LIVE VAULTS.

DRAWN BY: WR	<b>PROTOCOL FOR CONDUIT PENETRATIONS INTO VAULTS</b>	<b>ENERGY SERVICES</b>	
APPRD. BY: KDH			<b>DWG #7</b>
REV #: 1			7/16/2018

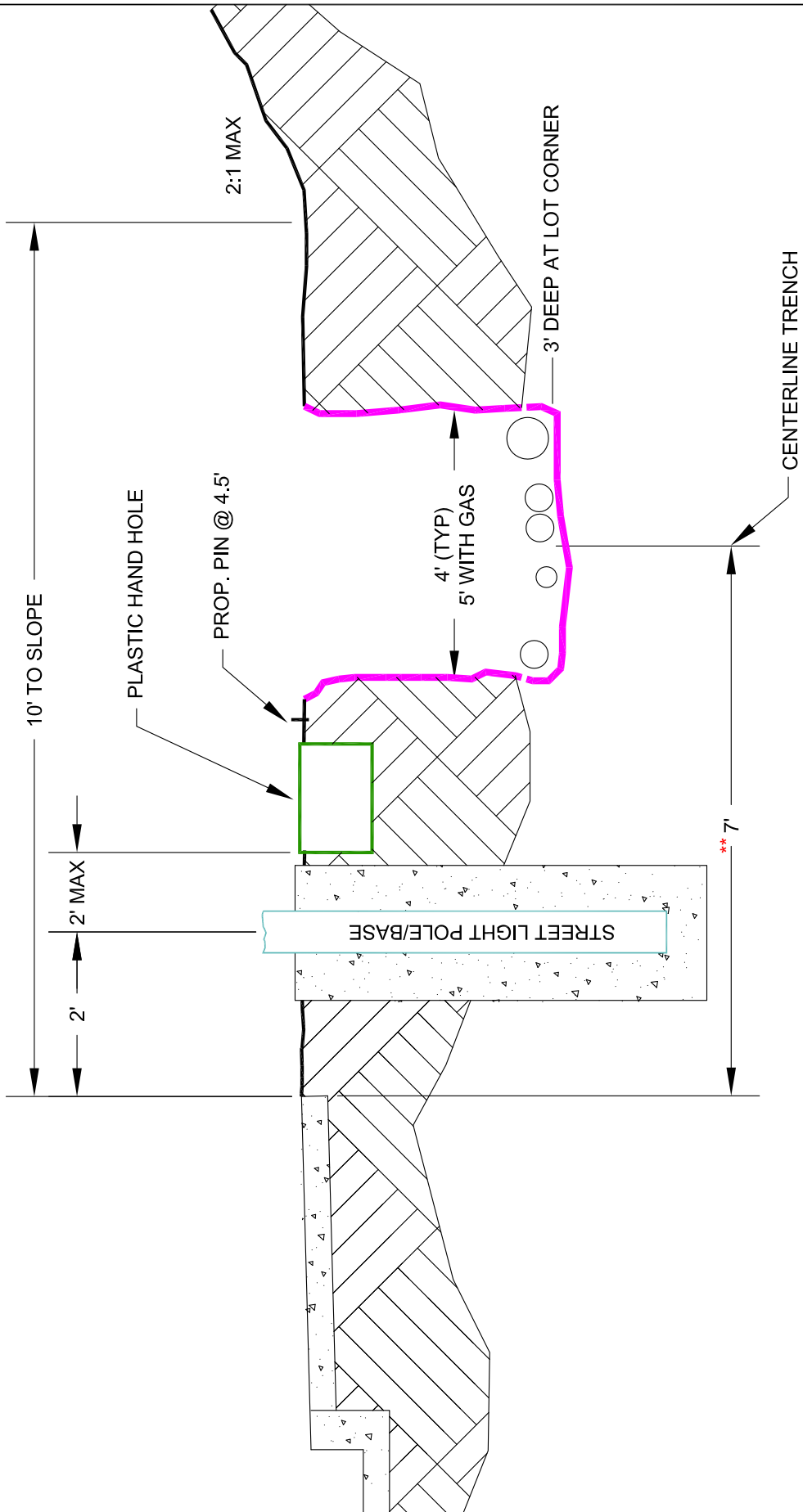

NOTE #1: FOR COMPLETE STREET LIGHT INFORMATION OBTAIN THE BELOW LISTED ATTACHMENTS FROM ENERGY SERVICES OR ON LINE:  
 "TECHNICAL SPECIFICATION FOR THE INSTALLATION OF STREET LIGHTING - TS-STRTLTL"  
 "MATERIAL SPECIFICATION FOR STREET LIGHTING - MS-STRTLTL"

\*\* DIMENSION CAN VARY DEPENDING UPON RIGHT OF WAY WIDTH BUT TYPICALLY CENTERLINE TRENCH IS 2 1/2'-3' INTO PROPERTY.

DRAWN BY: WR

APPRD. BY: KDH

REV #: 1

STREET LIGHT BASE & JUNCTION  
 RELATIVE TO ELECTRICAL



ENERGY  
 SERVICES

12/17/2010

DWG #8

SHT: 1 OF 1



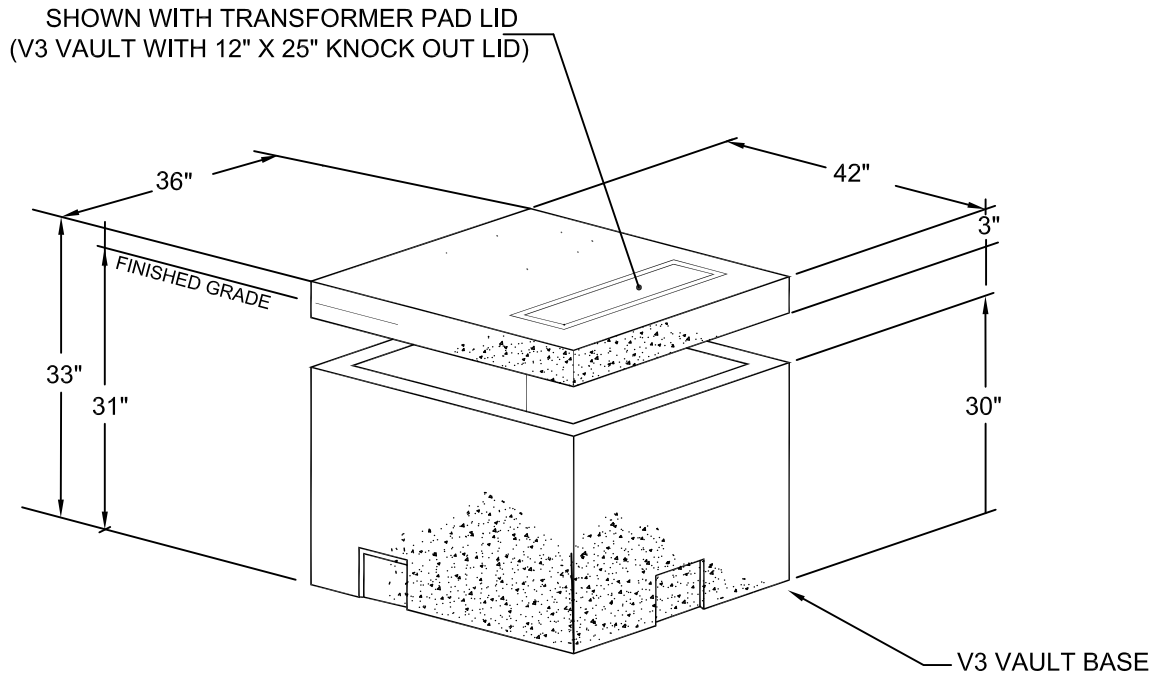

**V3 CONCRETE VAULT DETAIL**  
**SHOWN WITH KNOCK OUT LID (i.e. V3KO)**  
 SEE DWG #15 FOR VENDORS

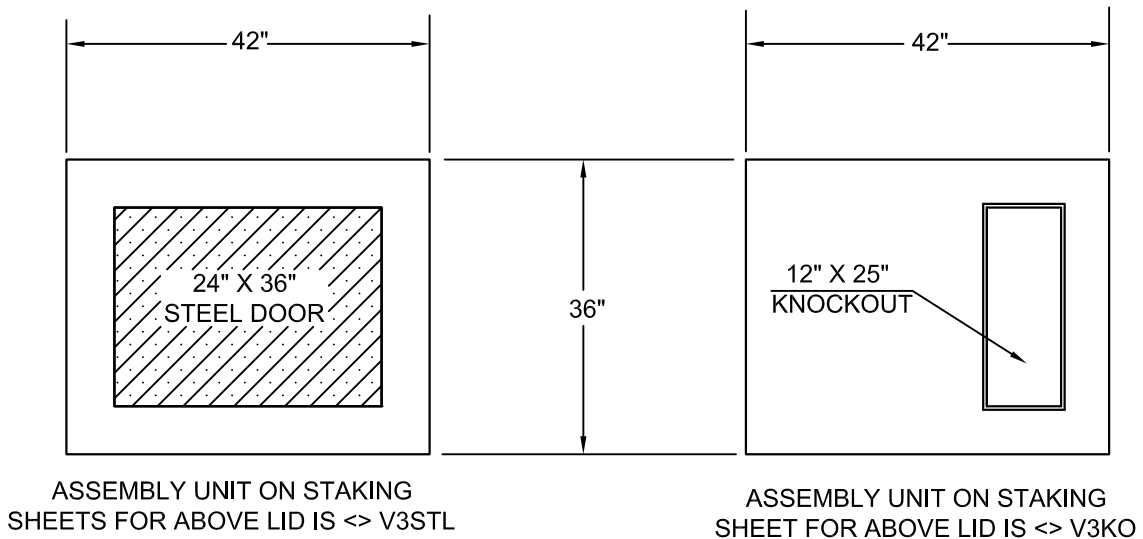

NOTE 1: THE V3KO VAULT BASE AND LID IS USED FOR ALL SINGLE PHASE TRANSFORMERS.

NOTE 2: IN RESIDENTIAL PLATS, GROUNDING SHALL BE INSTALLED BY ENERGY SERVICES CREWS AFTER INSPECTION OF TRANSFORMER INSTALLATION.

DRAWN BY: WR

APPRD. BY: KDH

REV #: 1

**V3 CONCRETE VAULT**



12/17/2010

**DWG #9**  
SHT: 1 OF 1

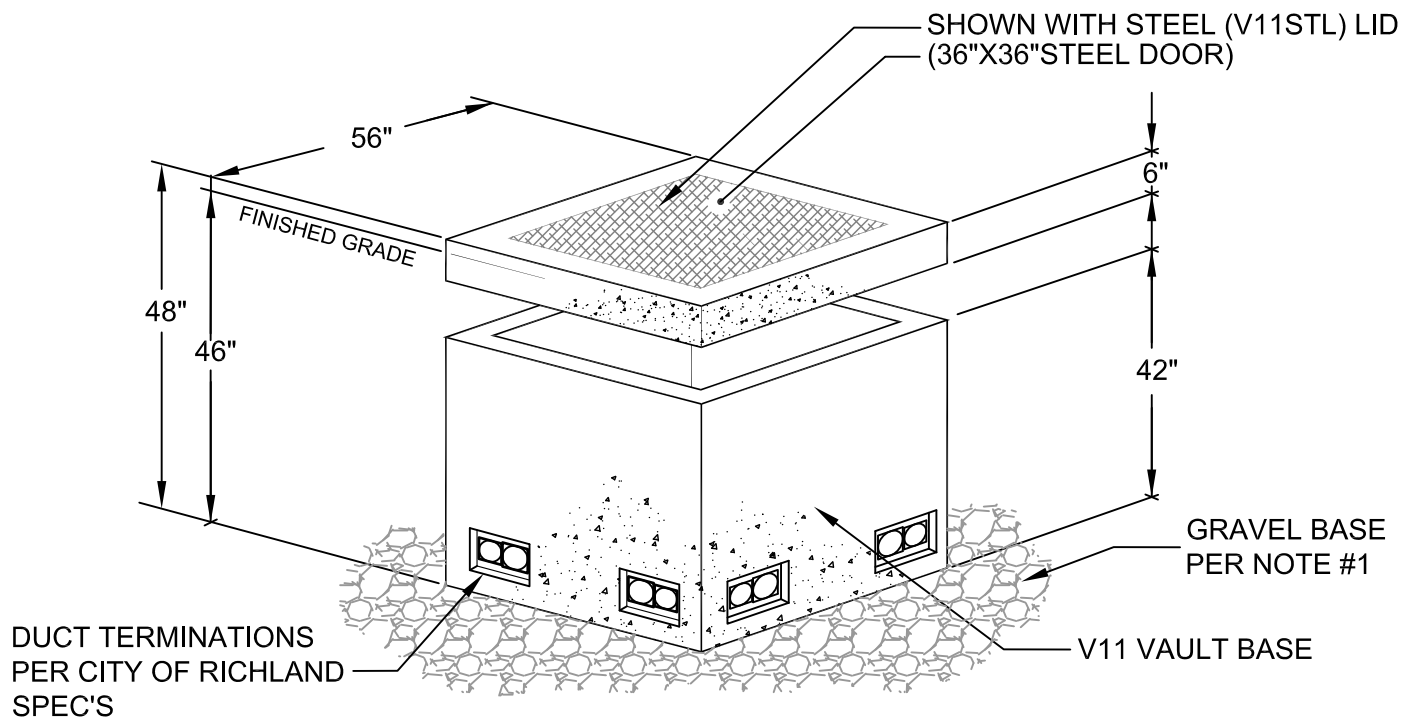

**V11 CONCRETE VAULT ASSEMBLY**  
**SHOWN WITH STEEL LID (i.e. V11STL)**  
 SEE DWG #15 FOR VENDORS

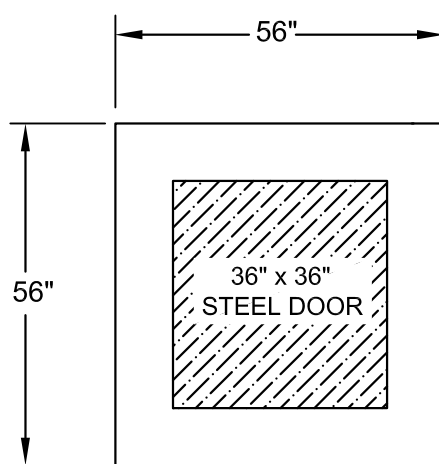

ASSEMBLY UNIT ON STAKING  
 SHEETS FOR ABOVE LID IS <> V11STL

NOTE 1: V11 CONCRETE VAULTS ARE TO BE SET ON 6" OF CRUSHED GRAVEL COMPACTED TO 95% DENSITY PER ASTM D-698. <> SEE DWG #12.

NOTE 2: FOR ANY SITUATION INVOLVING 3 Ø TRANSFORMERS PLEASE OBTAIN FROM ELECTRICAL ENGINEERING (OR ONLINE) THE HANDOUT "[SERVICE REQUIREMENTS-COMMERCIAL AND INDUSTRIAL BUSINESS DEVELOPMENTS](#)".

NOTE 3: IN RESIDENTIAL PLATS, GROUNDING SHALL BE INSTALLED BY ENERGY SERVICES CREWS AFTER INSPECTION OF TRANSFORMER INSTALLATION.

DRAWN BY: WR	<b>V11 CONCRETE VAULT</b>	 <b>ENERGY SERVICES</b>
APPRD. BY: KDH		
REV #: 1		12/17/2010

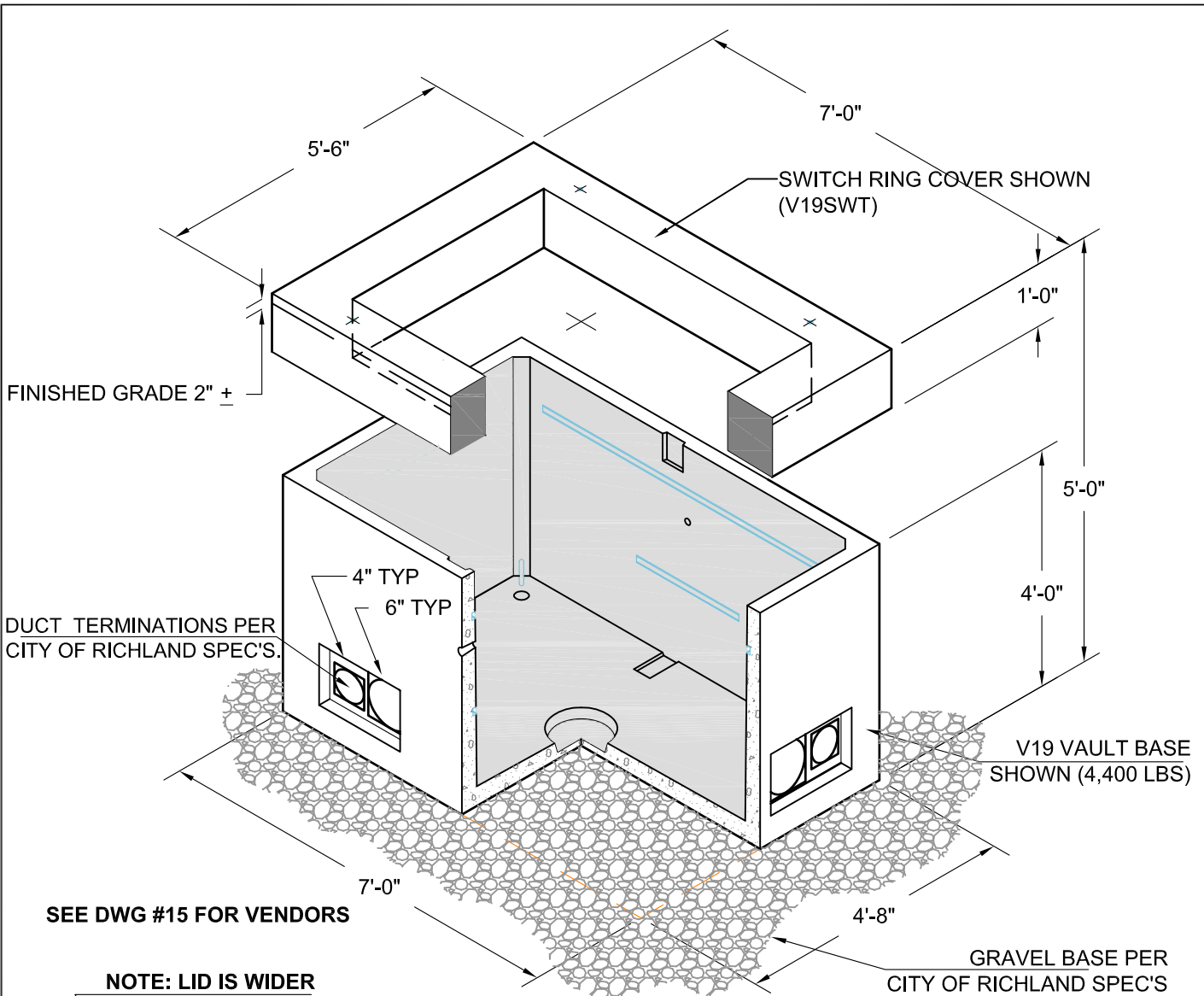

**NOTE: LID IS WIDER THAN VAULT BASE.**

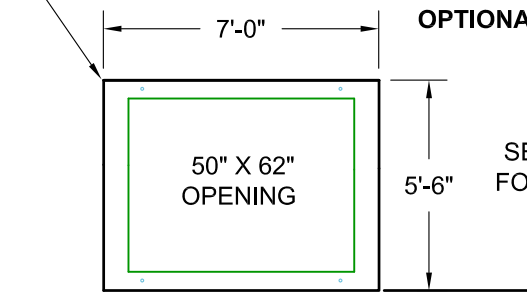

ASSEMBLY UNIT ON STAKING SHEETS FOR ABOVE LID IS <>V19SWT

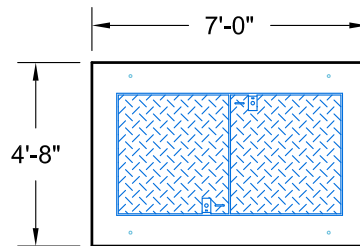

ASSEMBLY UNIT ON STAKING SHEETS FOR ABOVE LID IS <> V19STLS

- NOTE #1: THE V19 CONCRETE VAULTS ARE TO BE SET ON 6" OF CRUSHED GRAVEL COMPACTED TO 95% DENSITY PER ASTM D-698<> SEE DWG #12.
- NOTE #2: SWITCH RING VAULT COVER MUST HAVE OPENING COVERED WITH A SECURED LID OF PLYWOOD OR OTHER SUITABLE MATERIAL FOR SAFETY UNTIL CITY CREWS SET SWITCH CABINET.
- NOTE #3: IN RESIDENTIAL PLATS, GROUNDING SHALL BE INSTALLED BY ENERGY SERVICES CREWS AFTER INSPECTION OF TRANSFORMER INSTALLATION.

DRAWN BY: WR	<b>V19 CONCRETE VAULT</b>	 <b>ENERGY SERVICES</b>
APPRD. BY: KDH		
REV #: 1		12/17/2010

PLAN VIEW

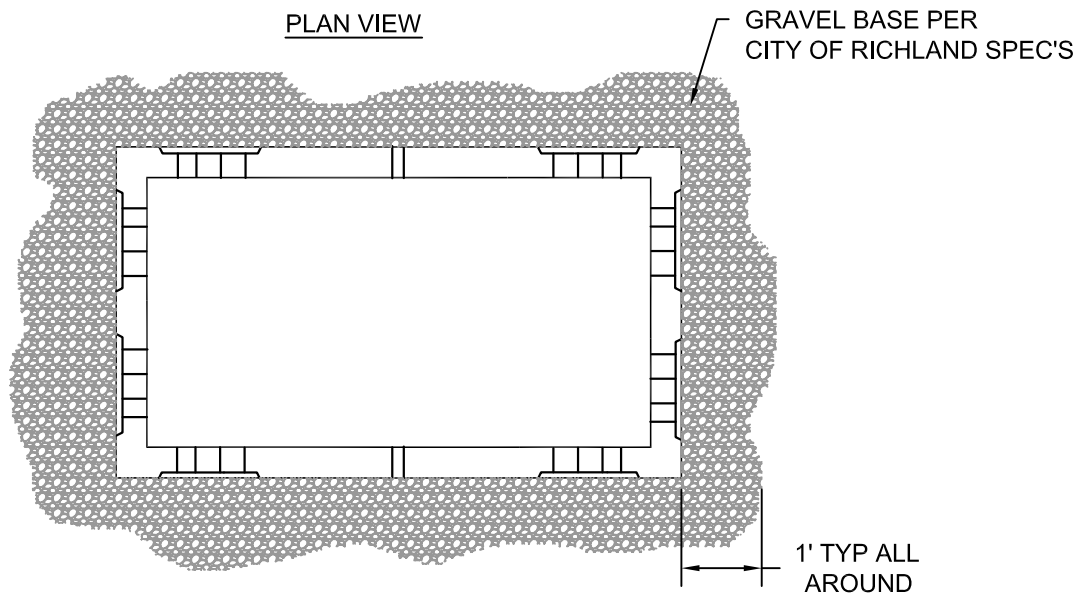

SIDE VIEW

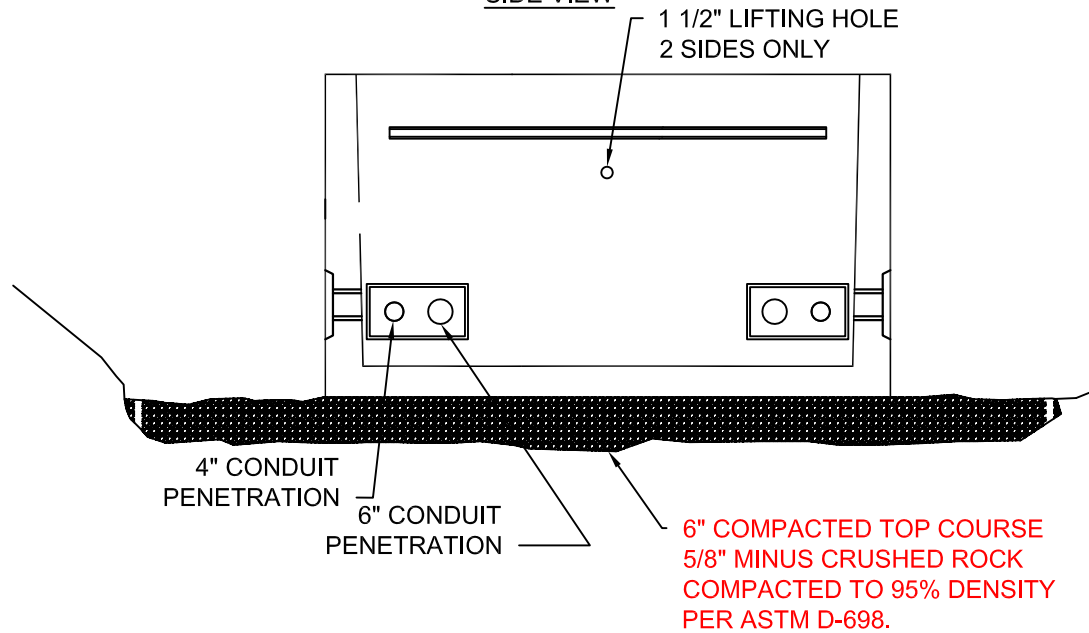

NOTE #1: V11 AND V19 VAULTS ARE TO BE SET ON 6" OF CRUSHED GRAVEL COMPACTED TO 95% DENSITY PER ASTM D-698.

NOTE #2: 6" GRAVEL BASE REQUIRED ONLY ON V11 AND V19 VAULTS ASSEMBLYS .

NOTE #3: GROUNDING TO BE INSTALLED BY ENERGY SERVICES CREWS AFTER INSPECTION OF INSTALLATION.

DRAWN BY: WR

APPRD. BY: KDH

REV #: 1

V11 & V19 VAULT  
COMPACTED GRAVEL BASE



ENERGY  
SERVICES

12/17/2010

**DWG #12**  
SHT: 1 OF 1

**UP TO 6-3" DUCTS**

4-3" SVC DUCTS  
TO VARIOUS LOTS  
(TYP. TO 4 LOTS)

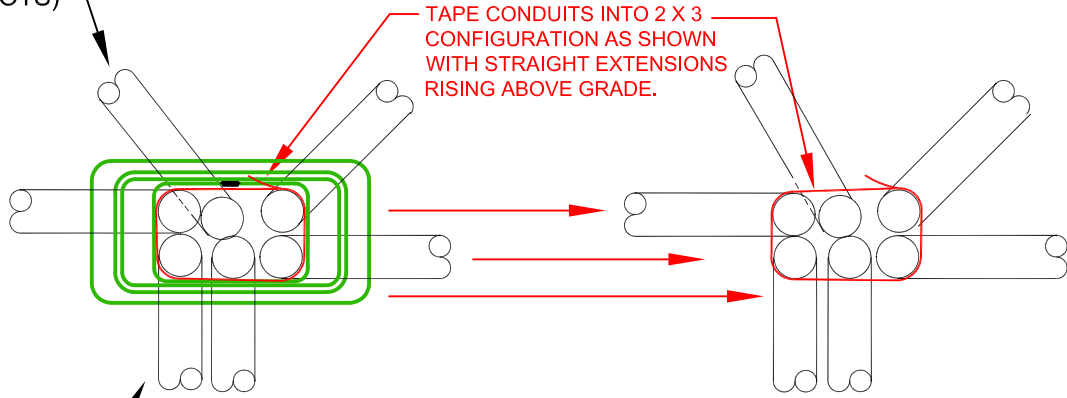

THESE DUCTS TYPICALLY  
CARRY 350TPX SECONDARY  
FEEDS FROM TRANSFORMER

**CURB THIS SIDE**  
**DETAIL OF TAPED PIPE TOWER**  
**FOR SECONDARY PEDESTALS**

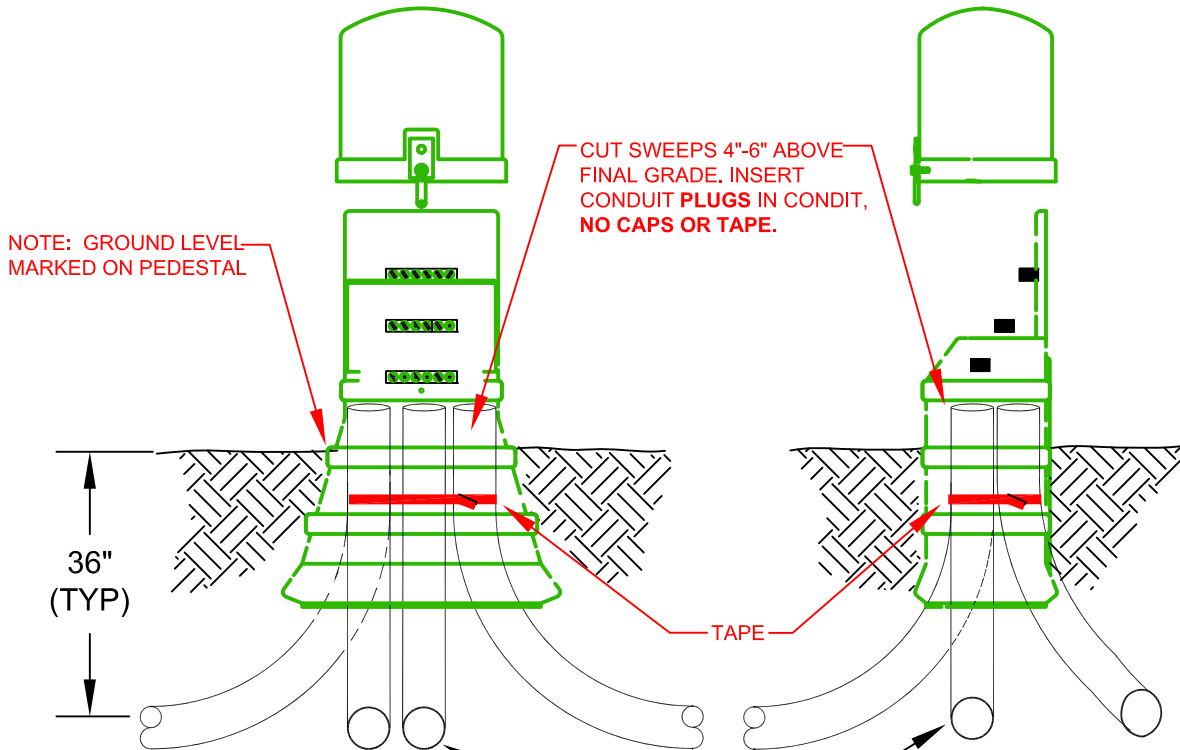

**USE 3" SCHD. 40 PVC DUCT**  
**WITH 36" RADIUS 90° SWEEP**  
**(TYP. ALL RISER SWEEPS)**

**NOTES:**

1. STANDARD WARNING STICKER TO BE PLACED ON PEDESTALS.
2. TAGS TO BE PLACED ON EACH CONDUCTOR REFERENCING HOUSE ADDRESS.
3. ENERGY SERVICES CREWS WILL TRIM CONDUITS TO PROPER HEIGHT AND INSTALL PEDESTALS.

DRAWN BY: DM

APPRD. BY: KDH

REV #: 1

**FIBERGLASS SECONDARY JUNCTION  
PEDESTAL WITH SERVICE CONNECTIONS**



**ENERGY  
SERVICES**

7/16/2018

**DWG #13**

SHT: 1 OF 1

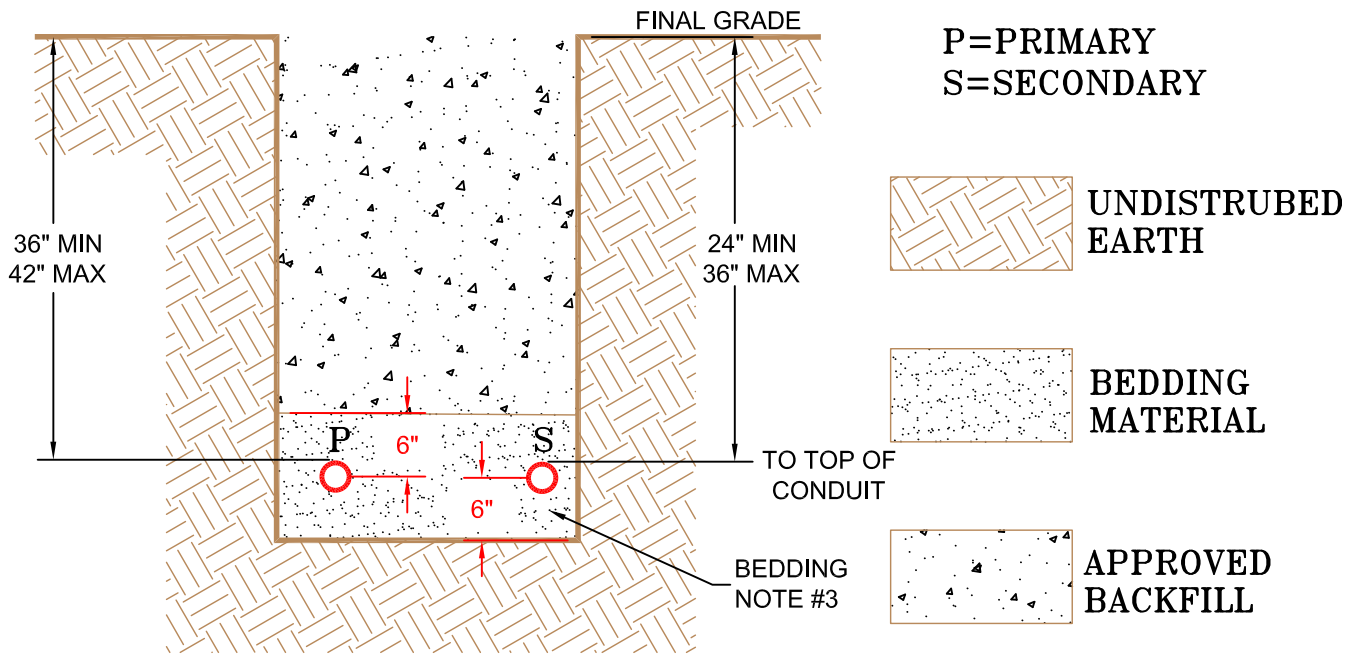

- NOTE #1: TRENCH DEPTH SPECIFIED FROM FINAL GRADE.
- NOTE #2: TO THE EXTENT POSSIBLE, TRENCH BOTTOMS SHALL BE LEVEL AND MADE OF WELL-TAMPED EARTH WITHOUT SHARP RISES AND DROPS IN ELEVATION. ROCK SPURS OR RIDGES SHALL NOT PROJECT INTO THE TRENCH.
- NOTE #3: BEDDING MATERIAL SHALL PASS THROUGH A 3/4" SIEVE FRAME AND BE PLACED ABOVE AND BELOW THE CONDUIT IN TWO BACKFILL OPERATIONS OF 6" LIFTS.
- NOTE #4: APPROVED BACKFILL SHALL BE FREE FROM STONES OR LUMPS EXCEEDING 3" AND FREE FROM SOD, FROZEN EARTH, ORGANIC MATERIALS AND CONSTRUCTION DEBRIS.
- NOTE #5: TRENCHES THAT EXCEED 48 INCHES IN DEPTH MUST COMPLY TO OSHA SHORING REQUIREMENTS.

DRAWN BY: JB
APPRD. BY: KDH
REV #: 0

**TRENCHING & BACKFILL  
DETAIL**

	<b>ENERGY SERVICES</b>
	<b>DWG #14</b> SHT: 1 OF 1

12/17/2010

# VENDORS LIST

**A. CONCRETE VAULTS AND LID VENDORS.**

**1) H2 Pre-cast, Inc**

4919 Contractors Drive  
E. Wenatchee, WA 98802

Contact: Justin Peters - Sales Manager, Phone (509) 884-6644 Fax (509) 884-4567 Cell (509) 669-1465

- a) V3 VAULT BASE .....E3 VAULT  
Steel Lid-concrete cover with 24" x 36" steel hatch ..... E3-2436SL  
Knockout lid-concrete cover w/ 12" x 25" knockout for single phase xfms ..... E3-1225
- b) V11 VAULT BASE-...with duct terminations per City of Richland Spec's..... 554-DT  
Steel Lid-concrete cover w/ 36" x 36" locking steel hatch..... 550-13
- c) V19 VAULT BASE-...with duct terminations per City of Richland Spec's.....575-DT  
Steel Lid-concrete cover with 2-36"x36" locking steel doors ..... H2 #570-23  
Switch Ring-Cover, switch ring, 66" x 84" w/ 50" x 62" opening(Specify: Richland Special) ....76-5062-12"  
Switch Ring-cover, 78"x84" w/ tapered block out, top 56"x 68", bottom 50"x 68" .....TPR8478-5068

**2) Old Castle Precast**

North 922 Camahan Rd.  
Spokane Valley, WA 99212

Contact: Jeff Cates - Sales Phone (509) 536-3304 Cell (509) 998-1469

- a) V3 VAULT BASE.....3642-LA  
Steel Lid-concrete cover with 24" x 36" steel door.....3642-2436P  
Knockout Lid-concrete cover w/ 12" x 25" knockout for single phase xfms.....3642-1225KO
- b) V11 VAULT BASE.....504-Richland  
Steel Lid-concrete cover w/ 36" x 36" locking steel hatch.....55-332P
- c) V19 VAULT BASE.....575-Richland  
Steel Lid-concrete cover with 2-36" x 36" locking steel doors.....57-2-332P  
Switch Ring-cover, switch ring, 66" x 84" w/ 50" x 62"opening.....57-V19SWT  
Switch Ring-cover, 78"X84" w/ tapered block out, Top 56" x 68", Bottom 50"x 68" .....contact mfg

**3) Reese Concrete Products**

1606 S Ely St.  
Kennewick, WA 99337

Contact : Bobby Bowling - General Manager, Phone (509) 586-3704 Cell (509) 627-9700

- a) V3 Vault Base.....E3R  
Steel Lid-concrete cover with 24" x 36" steel hatch .....E3-3642  
Knockout lid-concrete cover w/ 12" x 25" knockout for single phase xfms.....E3R-2512-T
- b) V11 VAULT  
BASE.....VB-554R  
Steel Lid-concrete cover w/ 36" x 36" locking steel hatch.....E3-3642

**NOTE: For any situation involving three-phase transformers, please refer to the information handout "SERVICE REQUIREMENTS-COMMERCIAL AND INDUSTRIAL BUSINESS DEVELOPMENTS" available from the City's Electrical Engineering Department or on line.**

DRAWN BY: DM	<b>VENDORS LIST</b> <b>CONCRETE VAULTS &amp; LIDS</b>		4/20/17	<b>DWG #15</b>
APPRD. BY: BT				SHT: 1 OF 1
REV #: 2				